

Power Transistors Characteristics

Power transistors are devices that have controlled turn-on and turn-off characteristics. These devices are used as switching devices and are operated in the saturation region resulting in low on-state voltage drop. **They are turned on when a current signal is given to base or control terminal.** The transistor remains on so long as the control signal is present. The switching speed of modern transistors is much higher than that of Thyristors and **are used extensively in dc-dc and dc-ac converters.** However, their voltage and current ratings are lower than those of thyristors and **are therefore used in low to medium power applications.**

Power transistors are classified as follows

- Bipolar junction transistors(BJTs)
- Metal-oxide semiconductor field-effect transistors(MOSFETs)
- Insulated-gate bipolar transistors(IGBTs)

Power BJT

The need for a large blocking voltage in the off state and a high current carrying capability in the on state means that a power BJT must have substantially different structure than its small signal equivalent. The modified structure leads to significant differences in the I-V characteristics and switching behaviour between power transistors and its logic level counterpart.

BJT Structure

To form a three terminal device with the terminals named as Emitter, Base and Collector, thin p-layer is sandwiched between two n-layers as shown in fig.1. in the power BJT, the following differences over conventional one are obvious:

- A power transistor is a vertically oriented four-layer structure of alternating p-type and n-type. **This is maximising the cross-section area results in current rating of**

BJT, minimize the on-state resistance, and thus reduce the power losses.

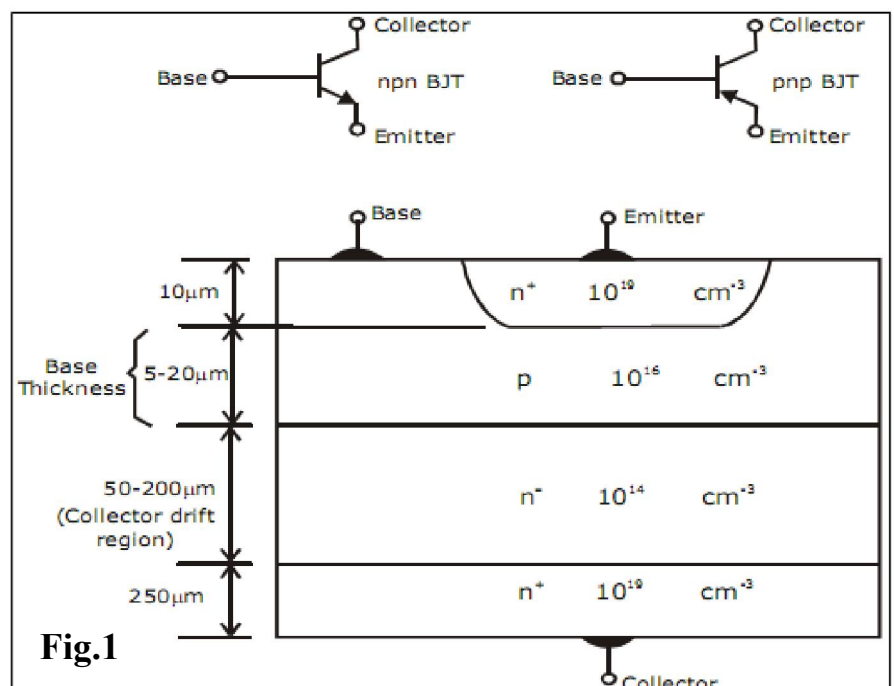

- The doping of emitter layer and collector layer is quite large typically 10^{19} cm^{-3}
- A special layer called the collector drift region (n^-) has a light doping level of 10^{14} .
- The thickness of the drift region determines the breakdown voltage of the transistor.
- The base thickness is made as small as possible in order to have good amplification capabilities, *however if the base thickness is small the breakdown voltage capability of the transistor is compromised.*

Steady State Characteristics

The power transistor has steady state characteristics almost similar to signal level transistors except that the V-I characteristics has a region of quasi saturation as shown by Fig.2

Three regions of operation for a BJT can be recognised:

Cutoff Region: When the base current (I_B) is zero, the collector current (I_C) is insignificant and the transistor is driven into the cutoff region. The transistor is now in the **OFF state**. The collector–base and base–emitter junctions are reverse-biased in the cutoff region or OFF state, and the transistor behaves as an *open switch*. In this region:

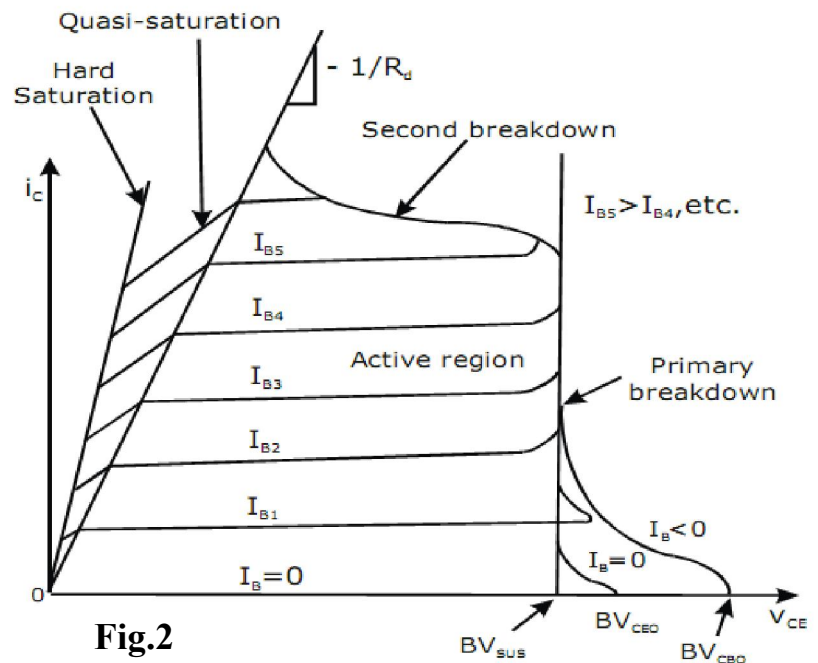

Fig.2

$I_C = 0$ and the collector–emitter voltage V_{CE} is equal to the supply voltage V_{CC}

Saturation Region: When the base current is sufficient to drive the transistor into saturation. During saturation, both junctions are forward-biased and the transistor acts like a *closed switch*. In the quasi saturation and hard saturation, the base drive is applied and transistor is said to be on. In this region:

$$I_C = V_{CC} / R_C \text{ and } V_{CE} = \text{zero}$$

Active Region: In the active region, the collector–base junction is reversed-biased and the base–emitter junction is forward-biased. The active region of the transistor is mainly used for *amplifier applications* and should be avoided for switching operation.

The power BJT is never operated in the active region (i.e. as an amplifier) it is always operated between cut-off and saturation.

Power BJT as a Switch

The transistor is used as a switch therefore it is used only between saturation and cutoff.

The following equations can be written:

$$I_B = \frac{V_B - V_{BE}}{R_B}$$

$$V_C = V_{CE} = V_{CC} - I_C R_C = V_{CC} - \beta \frac{R_C (V_B - V_{BE})}{R_B}$$

$$V_{CE} = V_{CB} + V_{BE} \quad \Rightarrow \quad \boxed{V_{CB} = V_{CE} - V_{BE} \quad \dots (1)}$$

as long as $V_{CE} > V_{BE}$ the Collector-Base junction is reverse biased and transistor is in active region,

The maximum collector current in the active region, for $V_{CB} = 0$ and $V_{BE} = V_{CE}$

$$I_{CM} = \frac{V_{CC} - V_{CE}}{R_C} \quad I_{BM} = \frac{I_{CM}}{\beta_F}$$

If $I_B > I_{BM} \rightarrow V_{BE} \uparrow, I_C \uparrow$ and V_{CE} falls below V_{BE} . This continues until Collector-Base junction is forward biased and the BJT goes into saturation region.

NOTE: The transistor saturation may be defined as the point above which any increase in the base current does not increase the collector current significantly.

The collector current is

$$I_{CS} = \frac{V_{CC} - V_{CESAT}}{R_C} \quad I_{BS} = \frac{I_{CS}}{\beta}$$

The ratio of I_B to I_{BS} is called to overdrive factor ODF.

$$\boxed{ODF = \frac{I_B}{I_{BS}}}$$

The ratio of I_C to I_{CS} is called forced β

$$\boxed{\beta_{forced} = \frac{I_{CS}}{I_B}}$$

The total power loss in the two functions is

$$\boxed{P_T = V_{BE} I_B + V_{CE} I_C}$$

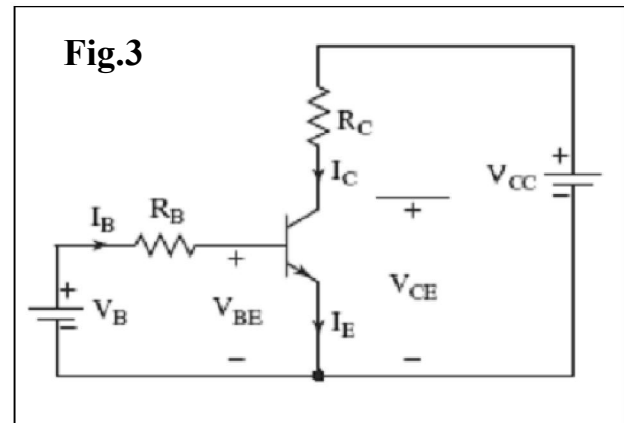

- A high value of ODF cannot reduce the CE voltage significantly.
- V_{BE} increases due to increase base current resulting in increased power loss.
- Once the transistor is saturated, the CE voltage is not reduced in relation to increase in base current.
- The power is increased at a high value of ODF, the transistor may be damaged due to thermal runaway.
- If the transistor is under driven I_B to I_{BS} it may operate in active region, V_{CE} increases resulting in increased power loss.

Example-1

The BJT is specified to have a range of 8 to 40. The load resistance in $R_e = 11\Omega$. The dc supply voltage is $V_{CC}=200V$ and the input voltage to the base circuit is $V_B=10V$. If $V_{CE(sat)}=1.0V$ and $V_{BE(sat)}=1.5V$. Find

- The value of R_B that results in saturation with a overdrive factor of 5.
- The forced β_f .
- The power loss P_T in the transistor.

Solution

$$(a) \quad I_{CS} = \frac{V_{CC} - V_{CE(sat)}}{R_C} = \frac{200 - 1.0}{11\Omega} = 18.1A$$

$$\text{Therefore} \quad I_{BS} = \frac{I_{CS}}{\beta_{min}} = \frac{18.1}{8} = 2.2625A$$

$$\text{Therefore} \quad I_B = ODF \times I_{BS} = 11.3125A$$

$$I_B = \frac{V_B - V_{BE(sat)}}{R_B}$$

$$\text{Therefore} \quad R_B = \frac{V_B - V_{BE(sat)}}{I_B} = \frac{10 - 1.5}{11.3125} = 0.715\Omega$$

$$(b) \quad \text{Therefore} \quad \beta_f = \frac{I_{CS}}{I_B} = \frac{18.1}{11.3125} = 1.6$$

$$(c) \quad P_T = V_{BE}I_B + V_{CE}I_C \quad P_T = 1.5 \times 11.3125 + 1.0 \times 18.1$$
$$P_T = 16.97 + 18.1 = 35.07W$$

Example-2

A simple transistor switch is used to connect a 24V DC supply across a relay coil, which has a DC resistance of 200Ω . An input pulse of 0 to 5V amplitude is applied through series base resistor R_B at the base so as to turn on the transistor switch. Sketch the device current waveform with reference to the input pulse. Calculate:

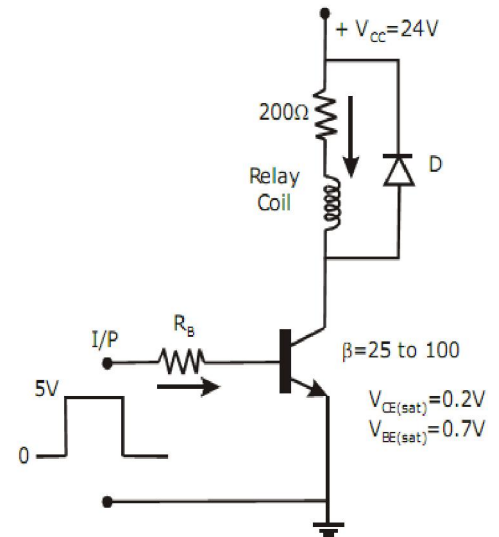

1. I_{CS}
2. Value of resistor R_B required to obtain over drive factor of two.
3. Total power dissipation in the transistor that occurs during the saturation state.

Solution

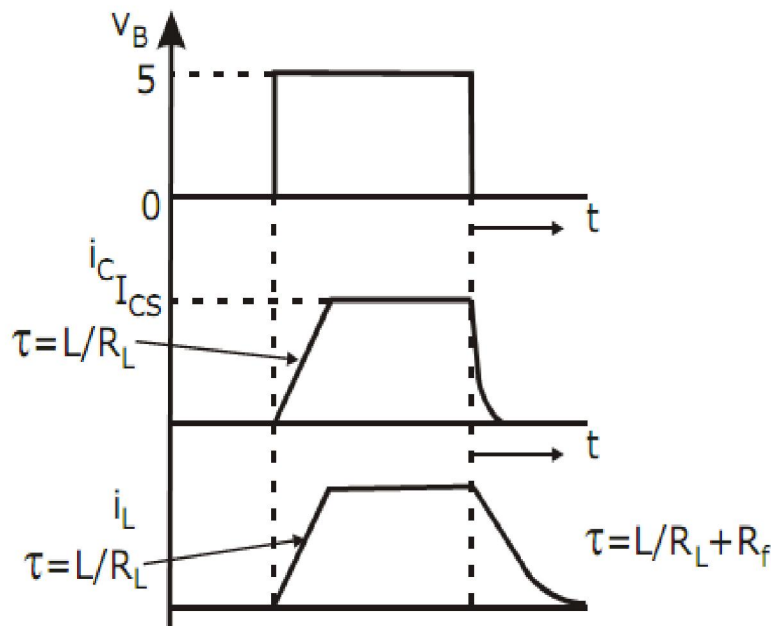

1)

$$I_{CS} = \frac{V_{CC} - V_{CE(sat)}}{R_C} = \frac{24 - 0.2}{200} = 0.119A$$

2) Value of R_B $I_{BS} = \frac{I_{CS}}{\beta_{min}} = \frac{0.119}{25} = 4.76mA$

$$\therefore I_B = ODF \times I_{BS} = 2 \times 4.76 = 9.52mA \quad \therefore R_B = \frac{V_B - V_{BE(sat)}}{I_B} = \frac{5 - 0.7}{9.52} = 450\Omega$$

3) $P_T = V_{BE(sat)} \times I_B + V_{CE(sat)} \times I_{CS} = 0.7 \times 9.52 + 0.2 \times 0.119 = 6.68W$

Self-assessments;

The β of a bipolar transistor varies from 12 to 75. The load resistance is $R_C = 1.5\Omega$. The dc supply voltage is $V_{CC}=40V$ and the input voltage base circuit is $V_B=6V$. If $V_{CE(sat)}=1.2V$, $V_{BE(sat)}=1.6V$ and $R_B=0.7\Omega$ determine

- The overdrive factor ODF.
- The forced β_f .
- Power loss in transistor P_T

For the transistor switch as shown in figure

- Calculate forced beta, β_f of transistor.
- If the manufacturers specified β is in the range of 8 to 40, calculate the minimum overdrive factor (ODF).
- Obtain power loss P_T in the transistor.

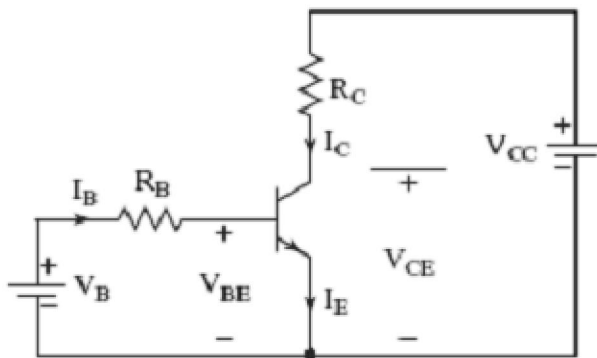

$$V_B = 10V, \quad R_B = 0.75\Omega,$$

$$V_{BE(sat)} = 1.5V, \quad R_C = 11\Omega,$$

$$V_{CE(sat)} = 1V, \quad V_{CC} = 200V$$

Switching Characteristics

A forward biased p-n junction exhibits two parallel capacitances; a **depletion layer capacitance** and a **diffusion capacitance**

a reverse biased p-n junction has only depletion capacitance.

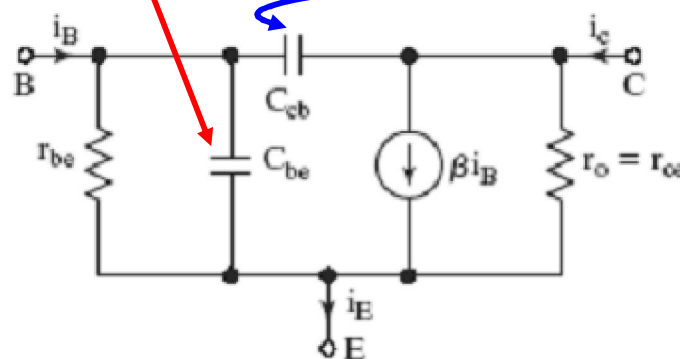

(a) Model with current gain

under transient conditions, they influence turn-on and turn-off behaviour of the transistor.

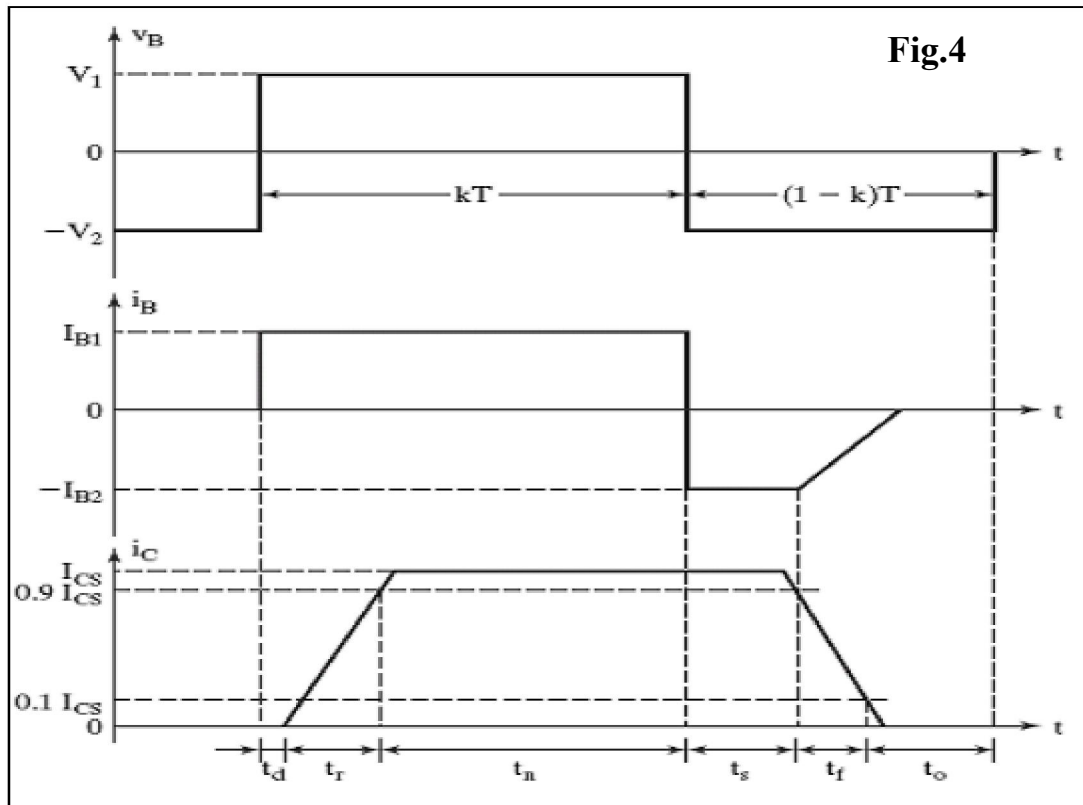

The Switching Times of BJT is shown in fig.4. from this figure it can be seen that:

- Due to internal capacitances, the transistor does not turn on instantly.
- V_B rises from zero to V_1 and the base current rises to I_{B1} , the collector current does not respond immediately.
- The delay is due to the time required to charge up the BEJ to the forward bias voltage $V_{BE}(0.7V)$.
- The collector current rises to the steady value of I_{CS} and this time is called rise time t_r .

The base current is normally more than that required to saturate the transistor. As a result, excess minority carrier charge is stored in the base region. The higher the ODF, the greater is the amount of extra charge stored in the base. This extra charge which is called the saturating charge is proportional to the excess base drive.

this extra charge which is called the saturating charge is proportional to the excess base drive and the corresponding current I_e .

$$I_e = I_B - \frac{I_{CS}}{\beta} = ODF \cdot I_{BS} - I_{BS} = I_{BS} (ODF - 1)$$

Saturating charge $Q_S = \tau_s I_e = \tau_s I_{BS} (ODF - 1)$ where τ_s is known as the storage time constant.

When the input voltage is reversed from V_1 to $-V_2$, the reverse current $-I_{B2}$ helps to discharge the base. Without $-I_{B2}$ the saturating charge has to be removed entirely due to recombination and the storage time t_s would be longer. Once the extra charge is removed, BEJ charges to the

input voltage $-V_2$ and the base current falls to zero. t_f depends on the time constant which is determined by the reverse biased BEJ capacitance.

Example-3

For a power transistor, typical switching waveforms are shown. The various parameters of the transistor circuit are as under $V_{cc} = 220V$, $V_{CE(sat)} = 2V$, $I_{CS} = 80A$, $t_d = 0.4\mu s$, $t_r = 1\mu s$, $t_n = 50\mu s$, $t_s = 3\mu s$, $t_f = 2\mu s$, $t_0 = 40\mu s$, $f = 5Khz$, $I_{CEO} = 2mA$. Determine average power loss due to collector current during t_{on} and t_n . Find also the peak instantaneous power loss, due to collector current during turn-on time.

Solution

During delay time, the time limits are $0 \leq t \leq t_d$. Figure shows that in this time $i_c(t) = I_{CEO}$ and $V_{CE}(t) = V_{CC}$. Therefore instantaneous power loss during delay time is

$$P_d(t) = i_c V_{CE} = I_{CEO} V_{CC} = 2 \times 10^{-3} \times 220 = 0.44W$$

Average power loss during delay time $0 \leq t \leq t_d$ is given by

$$P_d = \frac{1}{T} \int_0^{t_d} i_c(t) v_{CE}(t) dt \quad P_d = \frac{1}{T} \int_0^{t_d} I_{CEO} V_{CC} dt \quad P_d = f I_{CEO} V_{CC} t_d$$

$$P_d = 5 \times 10^3 \times 2 \times 10^{-3} \times 220 \times 0.4 \times 10^{-6} = 0.88mW$$

During rise time $0 \leq t \leq t_r$

$$i_c(t) = \frac{I_{CS}}{t_r} t \quad v_{CE}(t) = \left[V_{CC} - \left(\frac{V_{CC} - V_{CE(sat)}}{t_r} \right) t \right]$$

$$v_{CE}(t) = V_{CC} + \left[V_{CE(sat)} - V_{CC} \right] \frac{t}{t_r}$$

Therefore average power loss during rise time is

$$P_r = \frac{1}{T} \int_0^{t_r} \frac{I_{CS}}{t_r} t \left[V_{CC} + \left(V_{CE(sat)} - V_{CC} \right) \frac{t}{t_r} \right] dt \quad P_r = f I_{CS} t_r \left[\frac{V_{CC}}{2} - \frac{V_{CC} - V_{CES}}{3} \right]$$

$$P_r = 5 \times 10^3 \times 80 \times 1 \times 10^{-6} \left[\frac{220}{2} - \frac{220 - 2}{3} \right] = 14.933W$$

Instantaneous power loss during rise time is

$$P_r(t) = \frac{I_{CS}}{t_r} t \left[V_{CC} - \frac{V_{CC} - V_{CE(sat)}}{t_r} t \right] = \frac{I_{CS}}{t_r} t V_{CC} - \frac{I_{CS} t^2}{t_r^2} \left[V_{CC} - V_{CE(sat)} \right]$$

Differentiating the above equation and equating it to zero will give the time t_m at which instantaneous power loss during t_r would be maximum.

Therefore
$$\frac{dP_r(t)}{dt} = \frac{I_{CS} V_{CC}}{t_r} - \frac{I_{CS} 2t}{t_r^2} \left[V_{CC} - V_{CE(sat)} \right]$$

At $t = t_m$,
$$\frac{dP_r(t)}{dt} = 0 \quad \text{Therefore} \quad 0 = \frac{I_{CS}}{t_r} V_{CC} - \frac{2I_{CS} t_m}{t_r^2} \left[V_{CC} - V_{CE(sat)} \right]$$

$$\frac{I_{CS}}{t_r} V_{CC} = \frac{2I_{CS} t_m}{t_r^2} \left[V_{CC} - V_{CE(sat)} \right] \quad \frac{t_r V_{CC}}{2} = t_m \left[V_{CC} - V_{CE(sat)} \right]$$

Therefore
$$t_m = \frac{t_r V_{CC}}{2 \left[V_{CC} - V_{CE(sat)} \right]}$$

$$= \frac{V_{CC} t_r}{2 \left[V_{CC} - V_{CE(sat)} \right]} = \frac{220 \times 1 \times 10^{-6}}{2 \left[200 - 2 \right]} = 0.5046 \mu s$$

Peak instantaneous power loss P_{rm} during rise time is obtained by substituting the value of $t = t_m$ in equation (1) we get

$$P_{rm} = \frac{I_{CS}}{t_r} \frac{V_{CC}^2 t_r}{2 \left[V_{CC} - V_{CE(sat)} \right]} - \frac{I_{CS}}{t_r^2} \frac{(V_{CC} t_r)^2 \left[V_{CC} - V_{CE(sat)} \right]}{4 \left[V_{CC} - V_{CE(sat)} \right]^2}$$

$$P_{rm} = \frac{80 \times 220^2}{4 \left[220 - 2 \right]} = 4440.4 W$$

Total average power loss during turn-on

$$P_{on} = P_d + P_r = 0.00088 + 14.933 = 14.9339 W$$

During conduction time $0 \leq t \leq t_n$

$$i_C(t) = I_{CS} \quad \& \quad v_{CE}(t) = V_{CE(sat)}$$

Instantaneous power loss during t_n is

$$P_n(t) = i_C v_{CE} = I_{CS} V_{CE(sat)} = 80 \times 2 = 160W$$

Average power loss during conduction period is

$$P_n = \frac{1}{T} \int_0^{t_n} i_C v_{CE} dt = f I_{CS} V_{CES} t_n = 5 \times 10^3 \times 80 \times 2 \times 50 \times 10^{-6} = 40W$$

ADVANTAGES OF BJT'S

- BJT's have high switching frequencies since their turn-on and turn-off time is low.
- The turn-on losses of a BJT are small.
- BJT has controlled turn-on and turn-off characteristics since base drive control is possible.
- BJT does not require commutation circuits.

DEMERITS OF BJT

- Drive circuit of BJT is complex.
- It has the problem of charge storage which sets a limit on switching frequencies.

It cannot be used in parallel operation due to problems of negative temperature coefficient.

POWER MOSFETS

Unlike the devices discussed so far, a power MOSFET is a *unipolar*, majority carrier, "zero junction," *voltage-controlled device*. Figures (a) and (b) below show the symbol of an N-type and P-type MOSFETs.

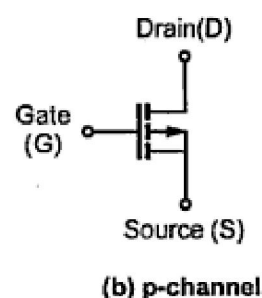
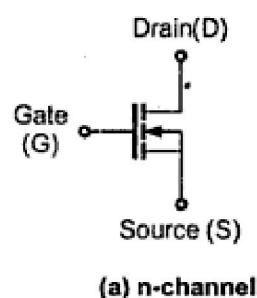

Enhancement Type MOSFET Construction

A slab of p-type material is formed and two n-regions are formed in the substrate. The source and drain terminals are connected through metallic contacts to n-doped regions, but the absence of a channel between the doped n-regions. The SiO₂ layer is still present

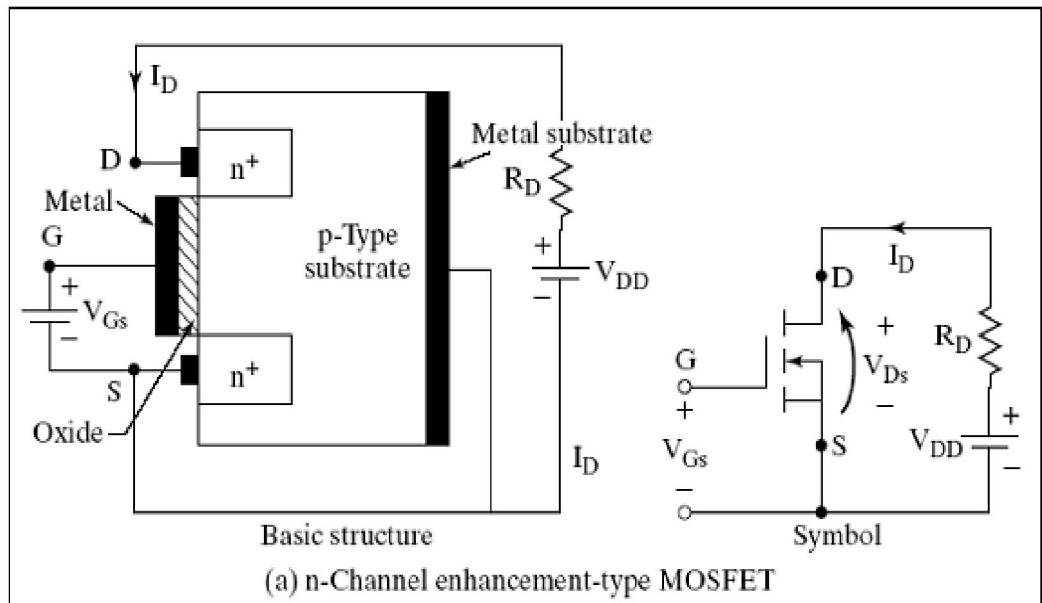

like in conventional MOSFET to isolate the gate metallic platform from the region between drain and source, but now it is separated by a section of p-type material.

With the normal forward polarity for V_{DD} on the MOSFET, but with V_{GS} = 0, the device is like an npn transistor with the drain to gate junction reverse-biased, and therefore no drain current flow.

With V_{GS} applied, making the gate positive with respect to the source, positive charge accumulates at the gate metallic surface, an electric field is created in the oxide layer, and negative charge accumulates at the p-structure surface in contact with the oxide layer. This negative charge repels holes in the p-structure and leaves a virtual n-type channel through which electrons can flow from source to drain, i.e. conventional current flow from drain to source. For the MOSFET to turn on, V_{GS} must exceed the threshold voltage V_T.

The linearized transfer characteristic of the MOSFET is shown in Fig. 5a, and the output, or drain-source, characteristic is shown in Fig. 5b.

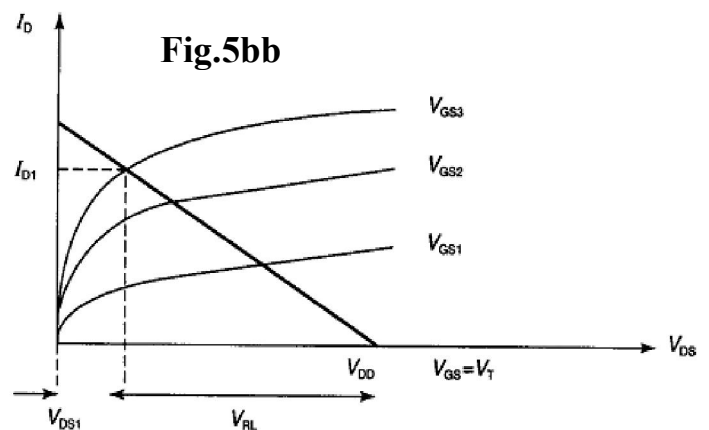
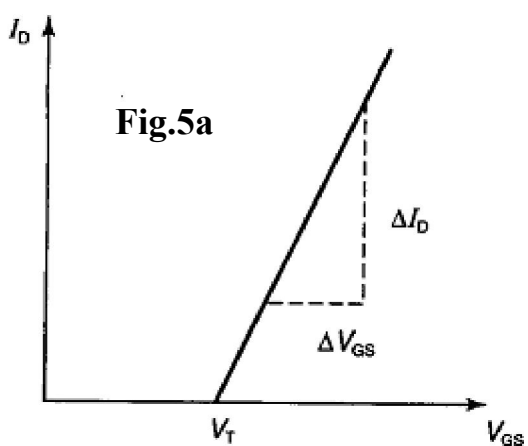

the load line can be superimposed on the output characteristic to give the operating point:

$$V_{DD} = I_D R + V_{DS}$$

$$I_D = (V_{DD}/R) - (V_{DS}/R)$$

At $I_D = 0$, $V_{DD} = V_{DS}$; at $V_{DS} = 0$, $I_D = V_{DD}/R$.

If the slope of the characteristic to the left of the intersection of the V_{GS} (working) curve with the load line, the so-called '**ohmic region**', is linearized then a much simpler solution is obtained.

Example-4

An IRF 150 power MOSFET has $V_{DD} = 20V$, $R_L = 0.5 \Omega$, at $V_{GS} = 8 V$, the on-state resistance is 0.1Ω . Determine the values of load current, device voltage drop, load power and circuit efficiency.

Solution

$$I_D = V_{DD}/(R_{DS(on)} + R_L)$$

$$= 20/(0.1 + 0.5) = 33.3A$$

$$V_{GS} = I_D \times R_{DS(on)} = 33.3 \times 0.1 = 3.33 V$$

$$P_L = (33.3)^2 \times 0.5 = 554 W$$

$$P_{in} = I_D^2 (R_{DS(on)} + R_L)$$

$$= (33.3)^2 \times (0.1 + 0.5) = 665 W$$

$$\text{Efficiency} = P_L/P_{in} = 554/665 = 0.833 \text{ or } 83.3\%.$$

Superimposing the load line gives $I_D = 33 A$ and $V_{DS} = 3.3 V$, the same values as the equivalent circuit.

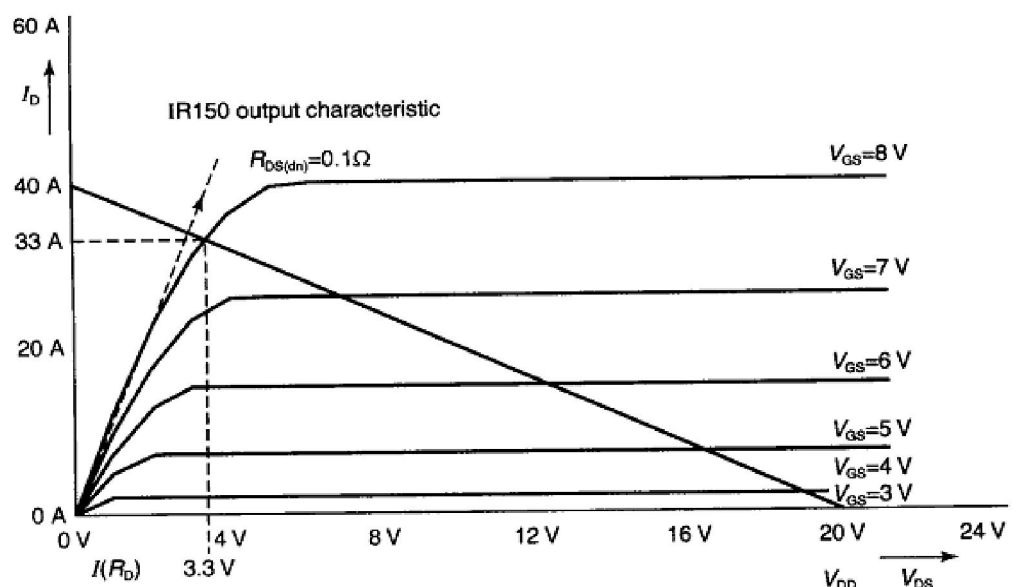

modulation of the Drain drift region so that on-state losses are reduced, especially when compared to an equally rated high voltage MOSFET.

- The MOSFET is a voltage controlled device where as BJT is a current controlled device.
- the difference between JFET and MOSFET There is no direct contact between the gate terminal and the n-type channel of MOSFET
- MOSFET's have high on state resistances due to which losses increase with the increase in the power levels. Their switching time is low and hence suitable for low power high frequency applications.
- the requirements of gate drive in MOSFET: The gate to source input capacitance should be charged quickly, MOSFET turns on when gate source input capacitance is charged to sufficient level, The negative current should be high to turn off MOSFET.
- the MOSFET used as a switch In the linear region.

In what way IGBT is more advantageous than BJT and MOSFET?

- It has high input impedance of the MOSFET and has low on-state voltage drop.
- The turn off time of an IGBT is greater than that of MOSFET.
- It has low onstate conduction losses and there is no problem of second Breakdown as in case of BJT.
- It is inherently faster than a BJT.

Self-assessments;

What would be the disadvantage of using a thyristor instead of a Mosfet in a d.c. chopper circuit?

A 2N6755 Harris n-channel Mosfet has a d.c. supply voltage of 60V, and a load resistance of 6Ω. With a gate-source voltage of 10V, the on-state resistance is 0.2Ω.

- Assuming that the Mosfet is acting as a simple on-off switch, determine the load current and efficiency.**
- The Mosfet above is now used in a 20kHz chopper circuit. Assuming the parameters remain unchanged, calculate the load power and efficiency at a chopper duty cycle of 0.4.**